

# V-Strike™ XS & XT

## UV External Duct Mount

### OWNER'S GUIDE

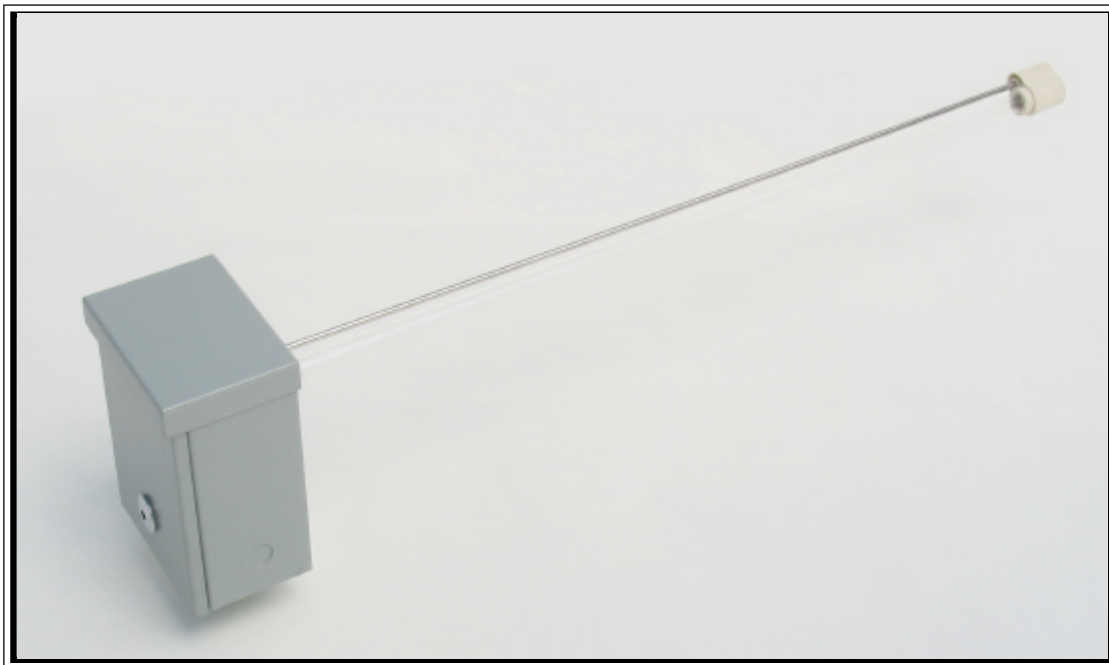

**ALTRU...V**  
REAL SCIENCE FOR HVAC MAINTENANCE

*Specifications subject to change without notice.  
Altru-V™ and V-Strike™ are brands owned by UVDI.  
Copyright © 2005 by UltraViolet Devices, Inc. All rights reserved.*

# V-Strike™ XS & XT

## Specifications

### Electrical Ratings:

#### Power Ratings:

**Note:** The V-Strike™ has two power settings:

120V Setting: 120 Vac, 60 Hz.

240V Setting: 240 Vac, 60 Hz.

The unit is design to be hard-wired to an appropriate electrical service in accordance with NEC.

#### Temperature Ratings:

Ambient Temperature Range: 40°F to 120°F (4°C to 49°C).

Lamp Temperature Range: 40°F to 120°F (4°C to 49°C).

Relative Humidity: Up to 95% rh, non-condensing.

#### Power Consumption:

Model	Input Current (A)	Lamp Wattage (W)
120V	0.7	36
240V	0.4	36



#### Approvals\*:

Underwriters Laboratories: File no. E212213. Category Code ABQK (Accessories, Air Duct Mounted) UL Standards: UL153, UL1598 & UL1995. The health aspects associated with the use of this product and its ability to aid in disinfection of environmental air have not been investigated by UL.

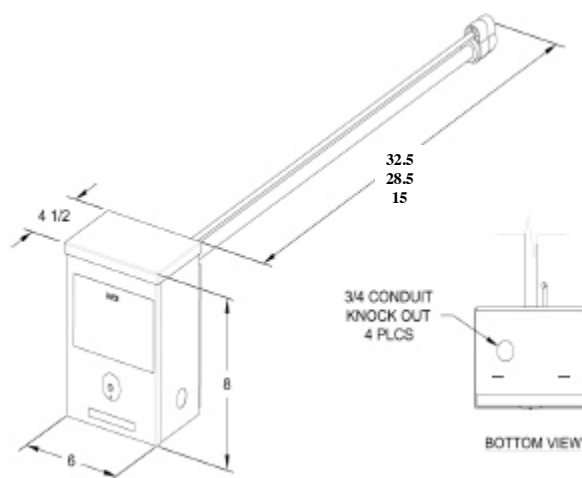

Fig. 1a. Shown: V-Strike™ XS in inches

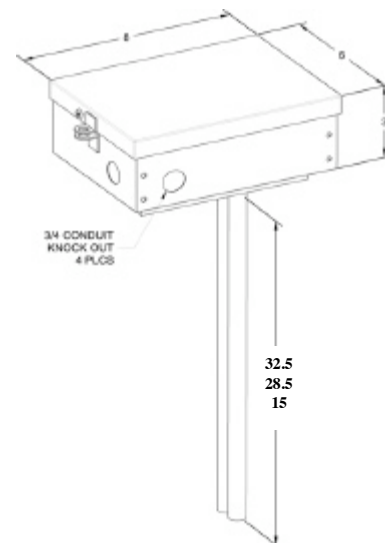

Fig. 1b. Shown: V-Strike™ XT in inches

# V-Strike™ XS & XT

## APPLICATION

When installed in forced air heating and cooling systems, the V-Strike™ kills airborne and surface microorganism contaminants. It can be used in both indoor and outdoor applications.

## INSTALLATION

### When Installing this Product:

1. Read these instructions carefully. Failure to follow them could damage the product or cause a hazardous condition.
2. Check the rating given in the instructions and on the product to make sure the product is suitable for your application.
3. Be sure to change the input power switch setting, accessible on the ballast unit in the electrical sub-panel, to match the electrical service ratings of the circuit where the unit is installed.
4. **To avoid accidental exposure to ultraviolet light, the power supply to this product must be electrically interlocked. Interlock switches must be installed at any access panel or door within view of the lamp.**
5. Installer must be a trained, experienced service technician.
6. After installation is complete, check out product operation as provided in these instructions.
7. If HVAC system has been in use prior to installation, it is recommended that debris and buildup on coils and HVAC system surfaces be cleaned.

## CAUTION

### Personal Injury Hazard.

#### Power supply can cause electrical shock.

Disconnect the power supply before beginning installation. Do not open the lamp knob; there are no user serviceable components inside. **Professional installation is required per NEC standards**



## WARNING

### UV Light Hazard.

#### Harmful to bare skin and eyes.

#### Can cause temporary or permanent loss of vision.

Never look at the lamps while illuminated.

Only view illumination by way of the light pipe indicator on the lamp knob.

To prevent exposure to ultraviolet light, disconnect power to the V-Strike™ before servicing any part of the heating/air conditioning system.

## Mounting Location



## CAUTION

### Equipment Damage Hazard.

#### Ultraviolet light can cause color shift or structural degradation of plastic HVAC materials.

Select mounting location that prevents exposure to plastic components with unknown resistance to ultraviolet light. Three-foot minimum is recommended between ultraviolet lamps and plastic-fabricated devices (such as non-fiberglass media filters).

# V-Strike™ XS & XT

## IMPORTANT

If mounting options are limited, protect plastic or rubber materials listed in CAUTION with ultraviolet-resistant material such as aluminum foil duct tape.

1. Choose a location that is readily accessible for regular inspection and cleaning. Figs. 2, 3 & 4 shows possible mounting locations.
2. **Be sure the duct mounting location is a minimum of 8 in. wide and proper depth (i.e. 37", 32" & 19"). See Fig.1a and 1b)**
3. Allow clearance in front of the device for removing the lamp assembly. See Fig. 1a and 1b for lamp assembly lengths.
4. Determine availability of 120 Vac or 240 Vac hard-wired electrical service for the installation. Electrical service must be installed in accordance with NEC.
5. Be sure the mounting location is an easily-accessible, flat mounting surface on the metal air duct of the HVAC system. Coil irradiation applications must be located so the lamp bathes the evaporator coil and drip pan with ultraviolet light.
6. Select a mounting location for the V-Strike™ (Mount the V-Strike™ XS only in vertical orientation and the V-Strike™ XT only in the horizontal orientation).

Sample: V-Strike™ XS

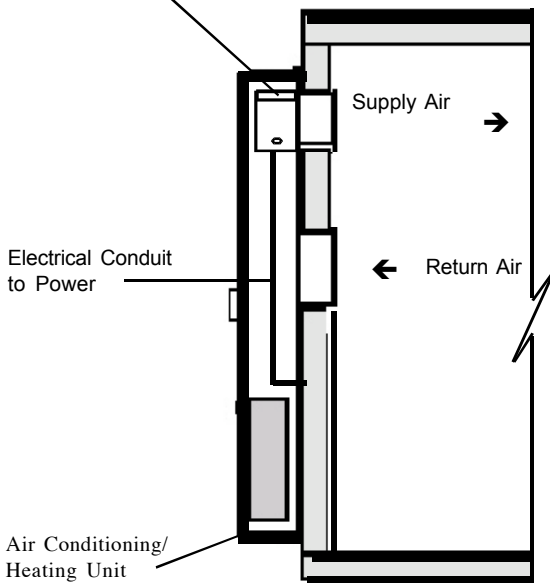

Fig. 2 Side View Mounting Option

Sample: V-Strike™ XT

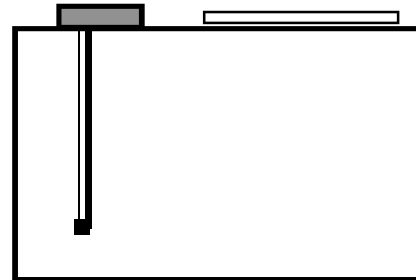

Fig. 3 Sample: V-Strike™ XT

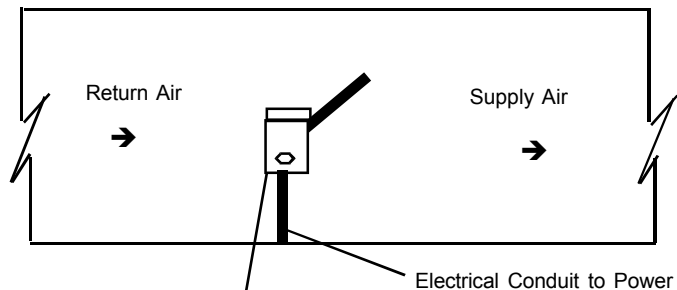

Fig. 4 Sample: "In Duct" - V-Strike™

# V-Strike™ XS & XT



## **Sharp Edges Hazard. Can cause personal injury.**

Be careful when inserting ultraviolet device into the sheet metal cutout. Wear protective gloves when working near sheet metal.

## **Duct Mounting**

Use the following instructions to mount the V-Strike™ on the air duct of an HVAC system:

1. Disconnect power to the HVAC system before installing the V-Strike™.
2. Place the V-Strike™ on the duct surface, centering the lamp hole on the duct.
3. Mark the location on the duct for the 2-1/4 in. diameter lamp hole and the unit mounting-screw pilot holes (4).
4. Cut the 2-1/4 in. lamp hole in the duct. Remove any burrs.
5. Use a 5/32 in. drill to provide pilot holes for the mounting screws, or use a power driver and self drilling screws.
6. Be sure the duct surface is flat after all holes are drilled.
7. Position the enclosure on the duct. Be sure the lamp hole in the duct aligns with the hole in the unit to allow lamp insertion.
8. Install the unit into the duct using the four no. 12 - 1 in. Phillips head sheet metal mounting screws (provided).
9. Tighten the screws to 12 to 14 lbs. so the space between the enclosure and duct is sealed, compressing the gasket.



## **Breakable Glass Hazard. Can cause personal injury.**

Be careful when inserting lamps into lamp base.  
Wear protective gloves when handling lamp(s).

## **MERCURY NOTICE**

This device contains mercury in the sealed ultraviolet lamp. Do not place your used lamp(s) in the trash. Dispose of properly.

### **Broken Lamp Cleanup.**

#### **Do not use a household vacuum.**

Sweep debris into a plastic bag and dispose of properly. Contact your local waste management authority for instructions regarding recycling and the proper disposal of old lamp(s).

## ***Electrical Installation***

### ***IMPORTANT***

Before installing the system, verify that the electrical service circuit where the system is installed is disconnected and not electrically energized.



**To avoid accidental exposure to ultraviolet light, the power supply to this product must be electrically interlocked. Interlock switches must be installed at any access panel or door within view of the lamp**

# V-Strike™ XS & XT

1. Remove the cover to the electrical sub-panel, exposing the ballast and installation wiring. See Fig. 5.
2. Set the input power switch setting, located on the ballast, to match the electrical service where the unit is installed (120 Vac or 240 Vac at 60 Hz).
3. Install all electrical service connections in accordance with NEC regulations. (not provided).
4. Be sure the electrical service enters the unit via a conduit hole (four conduit knockout holes are available in different locations of the enclosure. It is recommended that a weatherproof conduit adapter be used to protect the unit in outdoor installations.)
5. Connect the electrical service wires and external safety interlock to the unit according to the Installation wiring diagram in Fig. 5, using terminal block.
6. If the line voltage to Terminal 1 is already run through safety interlock switches, a jumper can be used to connect Terminal 3 to Terminal 4.
7. Install the electric sub-panel.
8. Remove the lamp assembly from the packaging; be careful not to touch the lamp surface with bare hands.
9. Carefully insert the lamp assembly into the enclosure. Avoid striking the lamp glass against the hole edges or other objects to prevent damage or breakage. If necessary, use a clean, dry cloth to help guide the lamp assembly during installation.
10. Align the tabs on the lamp knob with the slots in the lamp receptacle and insert the lamp until it stops.
11. Rotate the lamp assembly clockwise until it stops.
12. Connect the lamp assembly cord connector to the mating receptacle located on the exterior of the electrical sub-compartment.
13. Verify that the connector is fully inserted into the receptacle.

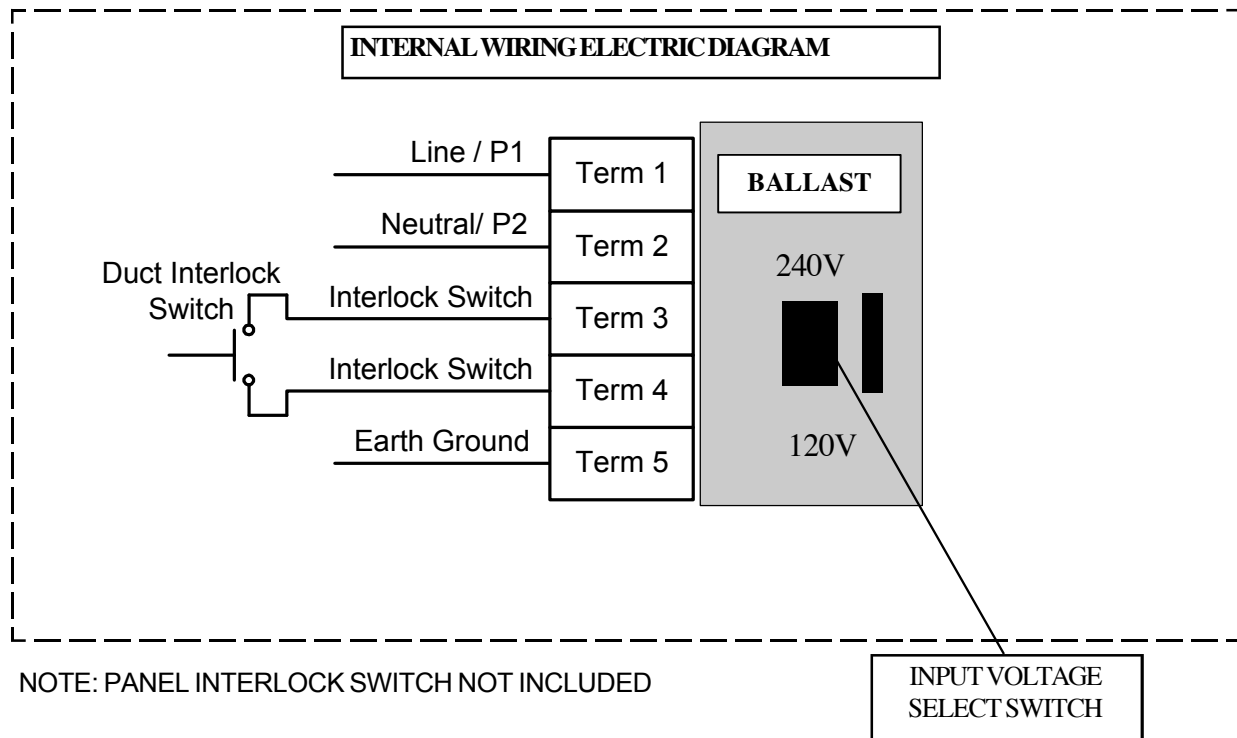

**FIG. 5 EXTERNAL DUCT MOUNT INSTALLATION WIRING DIAGRAM**

# V-Strike™ XS & XT



## WARNING

### **UV Light Hazard.**

**Harmful to bare skin and eyes.**

**Can cause temporary or permanent loss of vision.**

Never look at the lamps while illuminated.

Only view illumination by way of the light pipe indicator located on the lamp knob.

To prevent exposure to ultraviolet light, disconnect power to the V-Strike™ before servicing any part of the heating/air conditioning system.

To prevent accidental exposure to service personnel, install interlock switches and affix warning labels to HVAC equipment.

13. Reconnect the power to the HVAC system.
14. Choose a location on the adjacent HVAC equipment for the HVAC maintenance label included in the V-Strike™ packing box. Choose a location that a future service technician can easily see during all future HVAC maintenance or repair.
15. Adhere the HVAC maintenance label to the all HVAC equipment (selected in step 24) such as the furnace, air cleaner, humidifier or access panel. Fig. 5. Wiring diagram.

### **CHECKOUT**

The installer should verify that the ultraviolet lamp is operating only by viewing the light pipe indicator on the lamp knob. Do not attempt to look directly into the duct to see the illuminated ultraviolet lamp. The installer should orient the owner to the unit by showing them the blue glow of the light pipe indicator and discussing how to determine when the unit is functioning properly without looking directly into the duct to see the illuminated ultraviolet lamp. The installer should also emphasize the hot surface and electrical shock safety warnings. The installer should leave the Product Data with the owner and review the lamp cleaning and lamp replacement procedures.

### **TROUBLESHOOTING AND SERVICE**

The V-Strike™ has no field-serviceable parts. Lamp cleaning is recommended as routine maintenance four times a year or every three months (quarterly). Annual lamp replacement is required. See the Replacing Your Lamp (Annually) section for detailed procedural information.

### **MAINTENANCE**

You should regularly clean your ultraviolet lamps to maintain your air treatment system. Once every year, you must remember to replace your ultraviolet lamps.



## WARNING

### **Personal Serious Injury Hazard.**

**Power supply can cause severe electrical shock.**

Disconnect power supply before cleaning or replacing ultraviolet lamp.

Do not open electrical sub-panel after unit is installed.

# V-Strike™ XS & XT



## CAUTION

### **Breakable Glass Hazard.**

### **Can cause personal injury.**

Be careful when inserting lamp into lamp base.

Wear protective gloves when handling lamp.

## **Cleaning Your Lamps Every Three Months (Quarterly)**

Depending upon operating conditions, lamp cleaning is recommended as routine maintenance four times a year or every three months (quarterly). If the air stream is filtered, cleaning schedule may be reduced.

### **MERCURY NOTICE**

This device contains mercury in the sealed ultraviolet lamp. Do not place your used lamp in the trash.

Dispose of properly.

### **Broken Lamp Cleanup.**

### **Do not use a household vacuum.**

Sweep debris into a plastic bag and dispose of properly. Contact your local waste management authority for instructions regarding recycling and the proper disposal of old lamp.



## CAUTION

### **UV Lamp Burn Hazard. Harmful to bare skin. Can cause severe burns.**

Disconnect power 15 minutes before removing the ultraviolet lamp.

To clean your lamp:

1. Disconnect power to HVAC system.
2. Open the enclosure door.
3. Disconnect the lamp cable from the electrical sub-panel.
4. Allow the lamp to cool for at least 15 minutes.
5. Rotate the lamp knob until the tabs align with the slots; then carefully remove the lamp; be careful not to strike or hit the lamp glass on the enclosure edges.
6. Holding only the lamp knob, wipe the lamp glass using a soft cloth with window cleaner applied to the cloth. Do not touch the lamp surface with your hands; use only the cloth as oil in your hands can cause the lamps to soil quicker.
7. Wipe the lamp with a clean, dry cloth.
8. Insert the lamp into the enclosure as described in the Installation Duct Mounting section, steps 18



## WARNING

### **UV Light Hazard.**

### **Harmful to skin and eyes.**

### **Can cause temporary or permanent loss of vision.**

Never look at the lamp while illuminated.

Only view illumination by way of the light pipe indicator located on the lamp knob. To prevent exposure to ultraviolet light, disconnect power to the V-Strike™ before servicing any part of the heating/air conditioning system.

# V-Strike™ XS & XT

9. Reconnect the power to your HVAC system.
10. Verify that the ultraviolet lamp is operating only by viewing through the light pipe indicator on the lamp knob. Never look directly at your lamp while illuminated.
11. Replace and lock enclosure cover.



## CAUTION

### UV Lamp Burn Hazard.

**Harmful to bare skin.**

**Can cause severe burns.**

Disconnect power 15 minutes before removing ultraviolet lamp.

### Replacing Your Lamp (Annually)

Annual replacement of your lamp is required. To replace your lamp:

1. Disconnect power to HVAC system.
2. Open the enclosure door.
3. Disconnect the lamp cable from the electrical sub-panel. Allow the lamp to cool for at least 15 minutes.
4. Rotate the lamp knob until the tabs align with the slots; then carefully remove the lamp; be careful not to strike or hit the lamp glass on the enclosure edges.
5. Insert new lamp into enclosure as described in the Installation Duct Mounting section, steps 18 through 23.



## WARNING

### UV Light Hazard.

**Harmful to bare skin and eyes.**

**Can cause temporary or permanent loss of vision.**

Never look at the lamp while illuminated.

Only view illumination by way of the light pipe indicator located on the lamp knob. To prevent exposure to ultraviolet light, disconnect power to the V-Strike™ before servicing any part of the heating/air conditioning system.

6. Reconnect the power to your HVAC system.
7. Verify that your ultraviolet lamp is operating only by viewing through the light pipe indicator on the lamp.

## Replacement Lamps

Part #	Description
18-5000	V-Strike™ XS/XT 32.5" Lamp
18-5001	V-Strike™ XS/XT 28.5" Lamp
18-5002	V-Strike™ XS/XT 15" Lamp

# V-Strike™ XS & XT

## Equipment Warranty

**UltraViolet Devices, Inc. (UVDI), warrants to original Buyer for one year** from the date of original installation, or eighteen (18) months from date of shipment, whichever comes first, that its goods are free from defect in material and workmanship under normal use and service. **UVDI's** obligation under this warranty shall be limited to the repair or replacement of those goods which prove defective, provided that such products are installed, maintained, and operated for the purpose and in the manner intended and for which **UVDI** instructs or recommends. Neither **UVDI** nor its dealers shall be liable for any special or consequential damages directly or indirectly arising from the design, construction, installation, servicing, or operation of the goods. THIS IS **UVDI'S** SOLE WARRANTY. NEITHER **UVDI** NOR ITS DEALERS MAKE ANY OTHER WARRANTY OF ANY KIND, EXPRESSED OR IMPLIED. ALL IMPLIED WARRANTIES OF MERCHANTABILITY AND FITNESS FOR A PARTICULAR PURPOSE WHICH EXCEED **UVDI'S** AFFORESTATED OBLIGATIONS ARE HEREBY DISCLAIMED AND EXCLUDED FROM THIS WARRANTY.

**UVDI** AND ITS DEALERS' LIABILITY UNDER THIS WARRANTY SHALL IN NO EVENT EXCEED THE COST OF THE GOODS SOLD UNDER THIS CONTRACT OF SALE. **UVDI** neither assumes, nor authorizes any person to assume for it, any obligation in connection with the goods. This warranty shall not apply to any goods (a) which have been subjected to misuse, tampering, negligence, or accidents; or (b) the serial numbers of which have been altered, defaced, or removed; or (c) which have been used in a manner contrary to **UVDI's** instructions or recommendations. Buyer shall not return to **UVDI** any allegedly defective goods without **UVDI's** prior written authorization. This warranty may not be assigned or transferred.



Manufactured by:



26145 Technology Drive  
Valencia, CA 91355  
(877) PUREUVC  
(661) 257-4698 fax  
[www.uvdi.com](http://www.uvdi.com)

*Specifications subject to change without notice.  
Altru-V™ and V-Strike™ are brands owned by UVDI.  
Copyright © 2005 by UltraViolet Devices, Inc. All rights reserved.*